



Zinc Anodes Data Sheet

The **pml** range of zinc anodes is designed for use in a wide range of marine and shore-based applications.

Typical applications are pipelines, storage tank internals, offshore platforms, ships tanks, etc. The range is wide and we give below typical dimensions.

Alternative dimensions and weights are available to suit your specific requirements.

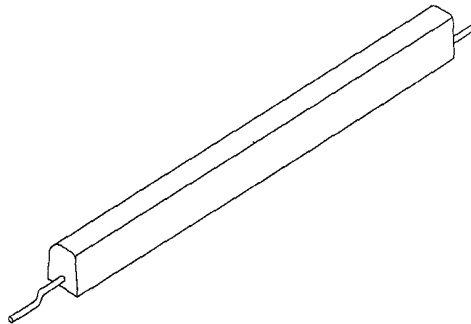

Attachment may be by direct welding or by purpose made clamps designed to suit the particular application.

Length mm	Section mm	Insert dia. mm	Net Weight mm	Gross Weight mm
mm	mm	mm	mm	mm
1220	63 x 57	12	21.5	23.0
1220	76 x 67	12	30.5	32.0
1220	82 x 81	12	40.5	42.0
1220	94 x 95	20	50.0	54.0
1225	60 x 60	12	30.4	31.9

These anodes may be prepackaged in a cotton bag with a backfill of 25% gypsum, 75% bentonite and 5% sodium sulphate mix to retain moisture around the installed anode, decrease the local anode to soil resistance and improve current output. None of these materials are hazardous.

Pipeline Maintenance Limited

Cathodic Protection Engineering and Materials Supply

11 & 12 Merlin Park, Mildenhall,
Suffolk, IP28 7RD, UK

Tel: +44 (0) 1638 711955

Fax: +44 (0) 1638 711953

Data Sheet ZNAN01 Rev 01

Page No 1 of 2

email: sales@pipelinemaintenance.co.uk
website: www.pipelinemaintenance.co.uk



The following alloy specification is widely used

Alloy Composition	US mil spec 18001K
Copper	0.005 max
Aluminium	0.10-0.50
Iron	0.005 max
Cadmium	0.025-0.07
Lead	0.006 max
Others(total)	0.10 max
Zinc	remainder
Nominal Capacity	780
AH/kg	
Solution Potential (m V) wrt	-1050
Ag/ Ag Cl	
Density (kg/m ³)	6920

This Alloy complies with US Military Specification A -18001 K (formerly 18001H) which is the accepted standard for all Zinc Anode manufacturers. It is a reliable material which has given good service over many years of Cathodic Protection experience.

For details of Price and Delivery please contact Pipeline Maintenance Limited at the address shown below.

Pipeline Maintenance Limited

Cathodic Protection Engineering and Materials Supply
 11 & 12 Merlin Park, Mildenhall,
 Suffolk, IP28 7RD, UK
 Tel: +44 (0) 1638 711955
 Fax: +44 (0) 1638 711953

Data Sheet ZNAN01 Rev 01
 Page No 2 of 2

email: sales@pipelinemaintenance.co.uk
 website: www.pipelinemaintenance.co.uk

